

[« Back to the overview](#)

CONTRACTS + CASE STORIES

AMARINTH DELIVERS TITANIUM PUMPS FOR FPSO VESSELS IN BRAZIL

03.03.2021

Amarinth has delivered an order of titanium pumps to VWS Westgarth that will be installed on two Petrobras FPSOs operating in Brazil.

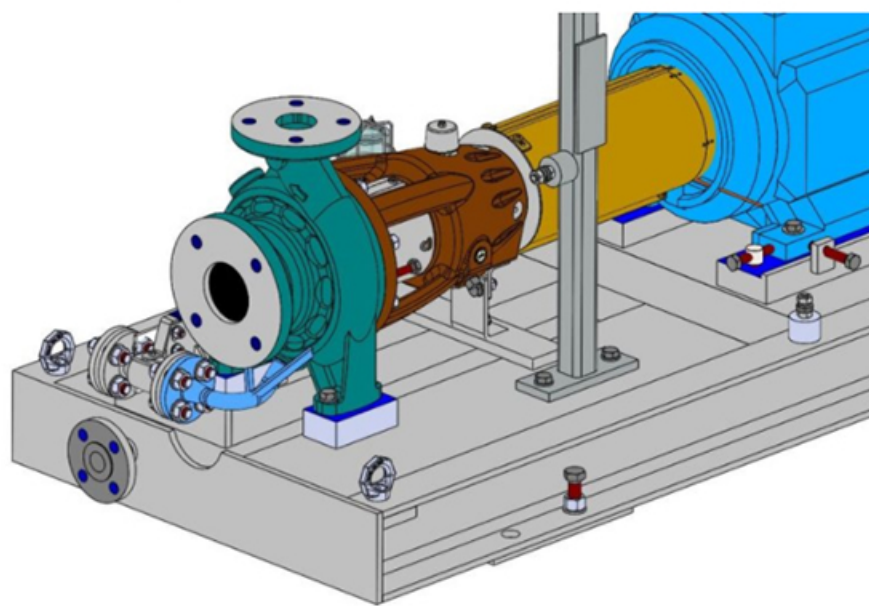

3D CAD model of an Amarith titanium pump being designed for VWS Westgarth to be installed aboard an FPSO vessel. (Image source: Amarith)

The order of four pumps from VWS Westgarth, the largest single supplier and operator of sulphate reduction membrane systems, was for chemically enhanced backwash pumps to be installed aboard two Floating Production Storage and Offloading (FPSO) vessels operated by Petrobras off the coast of Brazil.

The pumps are ATEX certified for hazardous areas and incorporate auto start stop modules for unattended operation. To handle the highly corrosive fluid, all wetted parts of the pumps are manufactured in titanium, including the casings, impellers and shafts. Titanium is a difficult material to work with and must be cast under a full vacuum using copper crucibles to prevent the molten titanium attacking the crucible walls. The UK has one of only a few foundries in the world with the capability to cast large titanium components. Amarith worked closely with this UK foundry to ensure an optimum design for the castings to maintain the correct flow of the molten titanium over changes of dimensions and directions.

Furthermore, Amarith had to deliver the pumps to a tight 28-week deadline amidst the Covid-19 pandemic. Amarith saw the scale and potential impact of the Covid-19 pandemic early in the outbreak and quickly leveraged its engineering and commercial agility and investment in remote working technologies to make the necessary changes to its business model, ensuring the company could work with its customers and suppliers to maintain critical on time delivery of pump orders.

Despite the engineering challenges, compounded by the Covid-19 pandemic, Amarith's strong relationship with its supply chain, and the Covid secure working practices it put in place, enabled the company to design, manufacture and deliver the pumps to meet the 28-week deadline for the project.

Oliver Brigginsshaw, Managing Director of Amarith, commented: "We are delighted to be supplying these pumps to VWS Westgarth. This order once again underlines our expertise in providing high-quality reliable pumps designed to meet the arduous conditions aboard FPSO vessels, along with our world leading capability in designing and manufacturing titanium pumps. With the changes we made to our business model early in the Covid-19 pandemic, we have been able to maintain our enviable on-time delivery record, not only for this order but to all of our customers over this past year."

Source: Amarith Ltd.

Directly to the product selection in **PUMPSELECTOR**

LATEST NEWS

- 17.03.2021 Grundfos Delivers Strong Financial Performance in 2020
- 17.03.2021 Pumps: Missing in Climate Action?
- 16.03.2021 Cowan Dynamics Presents Newly Expanded Brochure for the E2HR Series
- 16.03.2021 Scaba Heavy-Duty Agitators Save Energy in Sulphur Melters
- 16.03.2021 International Dialog More Important than Ever: ACHEMA Pulse Offers Forum for Discussion



EVENTS

MARCH 2021						
M	T	W	T	F	S	S
1	2	3	4	5	6	7
8	9	10	11	12	13	14
15	16	17	18	19	20	21
22	23	24	25	26	27	28
29	30	31	1	2	3	4

MON 22 ISH DIGITAL 2021
22 March - 26 March

JOB MARKET

05.06.2020 Software Developer Web Applications (m/f/d)
VSX - VOGEL SOFTWARE GmbH
Dresden, Germany

MORE ARTICLES ON THIS TOPIC



Technical News - Valves + Fittings

GEMÜ TUGELA DOUBLE-ECCENTRIC BUTTERFLY VALVE MEETS STRICTER TEMPERATURE AND PRESSURE REQUIREMENTS

12.02.2021 - GEMÜ, the valve specialist, offers a wafer version of the GEMÜ R470 Tugela series in nominal sizes of DN 50 to DN 600 with immediate effect. [Read more >>](#)

Cooperations - Corporate News

AMARINTH AND RENTCO AFRICA FORM STRATEGIC ALLIANCE TO PROVIDE AND FINANCE PUMP EQUIPMENT

08.02.2021 - Amarith has signed a strategic partnership with RentCo Africa Ltd under which the two companies will cooperate on strategic projects in the African territory to provide and finance centrifugal pumps and associated equipment on attractive financing terms. [Read more >>](#)

